

ITEM	PART ID	DESCRIPTION	MATERIAL	QTY
1	0001-1209	BOLT, BUTTON HD CAP, 3/8-16 X 1.50 LG, FT	SST	1
2	0002-8513	BOLT, FLAT HD SOC, 3/8-16 X 0.75 LG, FT	SST	4
3	0010-0453	O-RING -143, 2.425 ID X 0.103 CS	RUBBER	2
4	0010-0831	PLUG, PIPE, SOC, 1/8 NPT	NYLON	1
5	0010-0923	BOLT, HEX HD, 3/8-16 X 1.00 LG, FT	SST	2
6	0010-0924	BOLT, BUTTON HD CAP, 1/4-20 X 1.50 LG, FT	SST	7
7	0010-1141	FLANGE COVER, TRUMPET	URETHANE	2
8	0010-1143	TRUMPET HEAD ASSY		1
9	0010-1158	PLUG, PIPE, SOC, 3/8 NPT	NYLON	1
10	0010-1159	GASKET, TRUMPET HEAD FLANGE	RUBBER	1
11	0010-1215	AQUA-BATIC WELD ASSY	WELDED SST	1
12	0010-1222	REVOLUTION HUB ASSY	WELDED SST	1
13	0010-1223	SHIM WASHER	SST	2
14	0010-1236	UPPER BUSHING	ACETAL	1
15	0010-1237	LOWER BUSHING	ACETAL	1
16	0010-1239	LOCKING PLATE	SST	1
17	0010-1241	O-RING -332, 2.350 ID X 0.210 CS	RUBBER	1
18	0010-1455	SPIRAL HANDLE	URETHANE	1
19	NOZ-08001	NOZZLE, 2-1/2", 0.127 X 8 ORIFICE	ACETAL	1
20	NOZ-08012	NOZZLE, 2-1/2", BLANK	ACETAL	1
21	NUT-02101	NUT, NYLOCK, 1/4-20	SST	7
22	ORG-08336	O-RING -336, 2.850 ID X 0.210 CS	RUBBER	1
23	SBT-02106	BOLT, BUTTON HD TORX, 1/4-20 X 1.00 LG, FT	SST	6
24	WAS-02031	WASHER, FLAT, 3/8 (0.88 OD)	SST	2
25	WAS-02102	WASHER, FLAT, 1/4 (0.63 OD)	SST	14

REV	DESCRIPTION	DATE
A	INITIAL RELEASE	6/15/2016

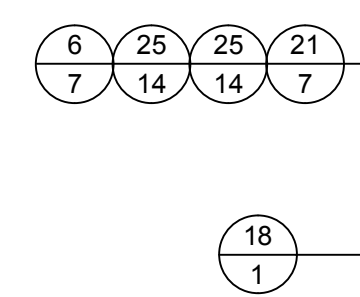
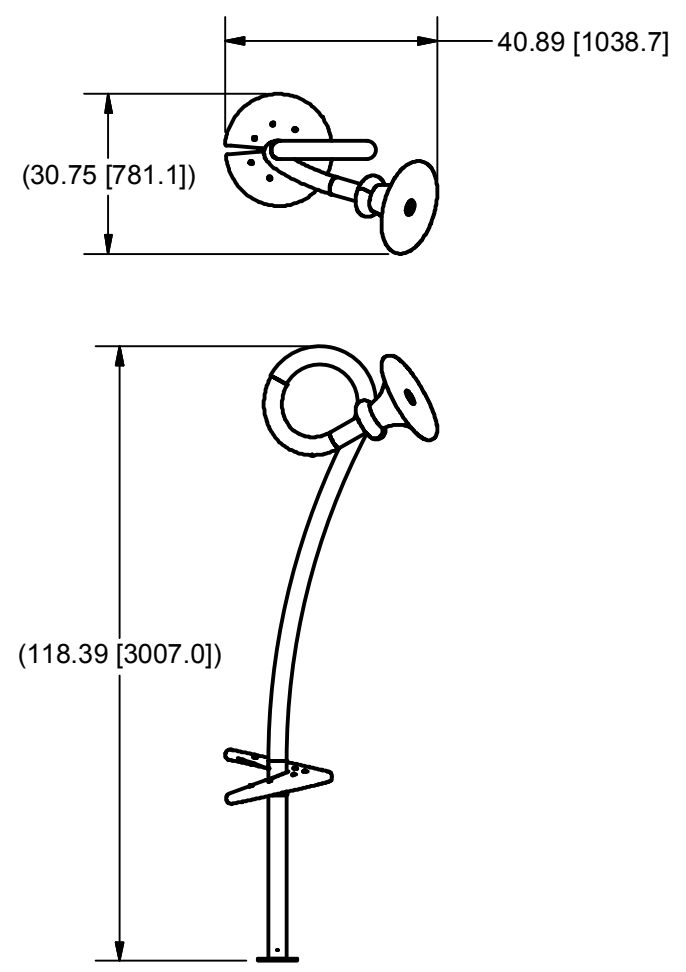
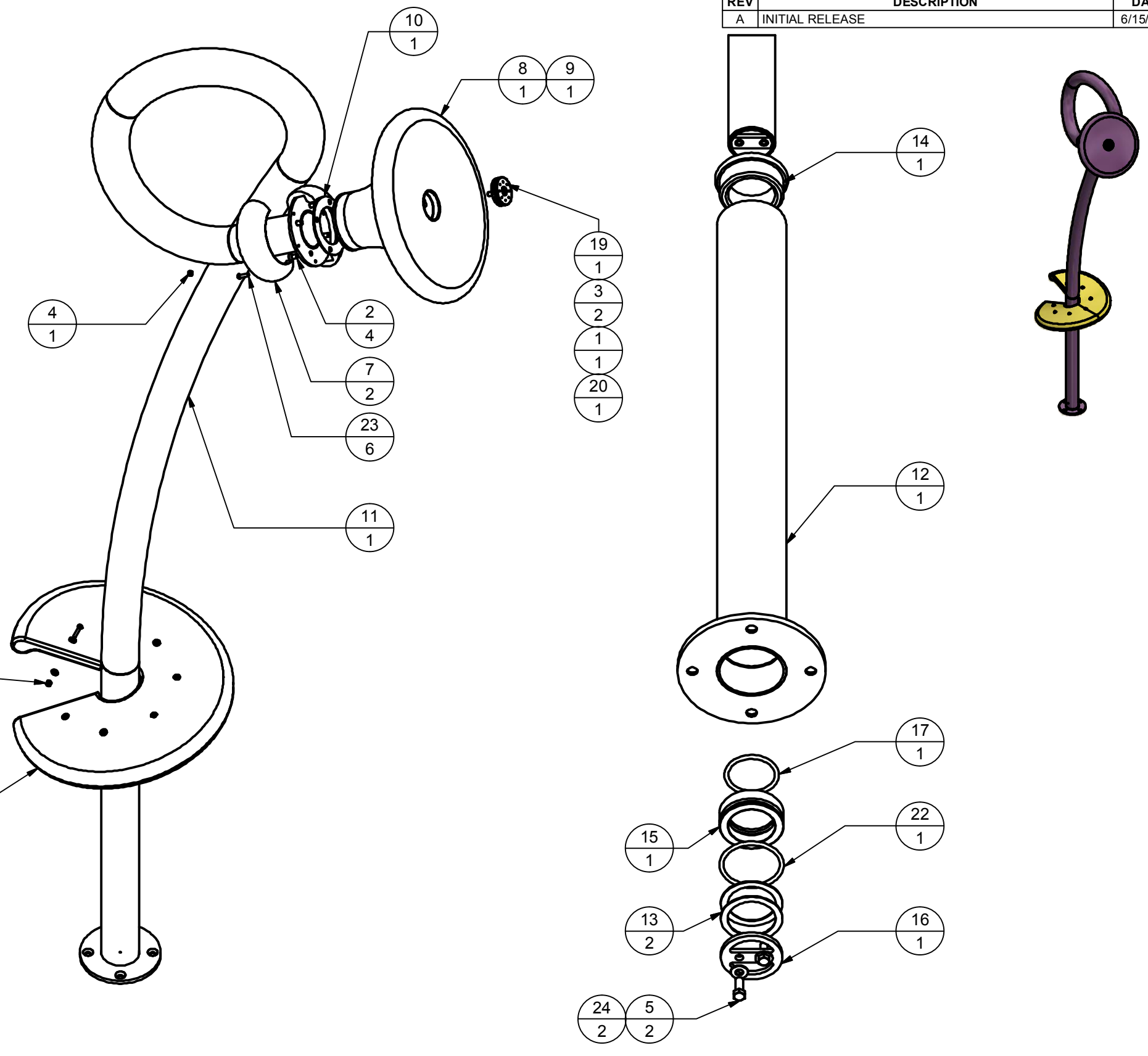

MASS: 124.8 lbmass	TOLERANCES UNLESS NOTED .X ±0.5 .XX (>10) ±0.05 .XX (<10) ±0.01 .XXX ±0.005 ANGULAR ±1° SURFACE FINISH 63µ in. ALL DIMENSIONS IN INCHES	DESIGNED: JASMAY	AQUA-BATIC ASSY
		DRAWN: JASMAY	
ALL PLANS AND DESIGNS AT ALL TIMES REMAIN THE PROPERTY OF THE WMI MANUFACTURING CORPORATION AND CANNOT BE USED OR REPRODUCED WITHOUT WRITTEN PERMISSION. 805 CROWLEY AVE. KELOWNA, BRITISH COLUMBIA CANADA, V1Y 7G6 P: 250-979-7205 F: 250-979-7215	THIRD ANGLE PROJECTION	CHECKED: NICMAY	CIRQUE
		DATE: 6/08/2016	DWG ID: 0010-1420